

BASE VIEW

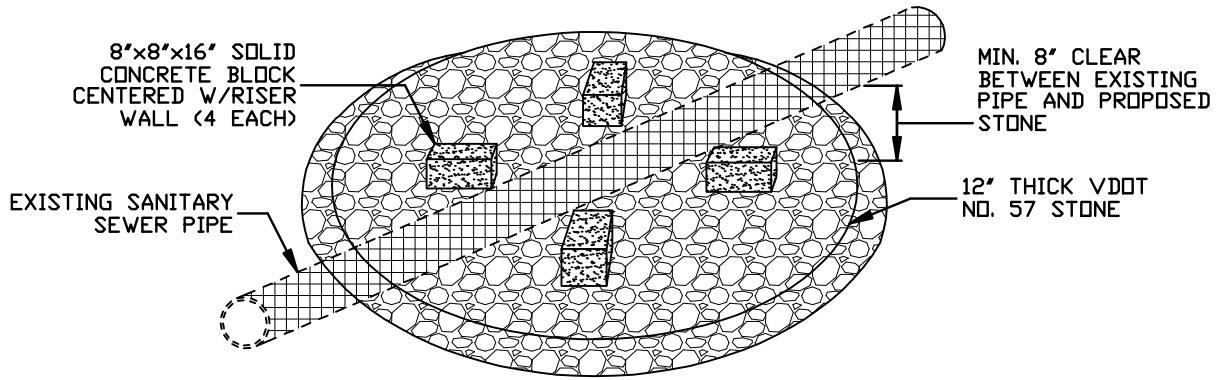

RISER VIEW

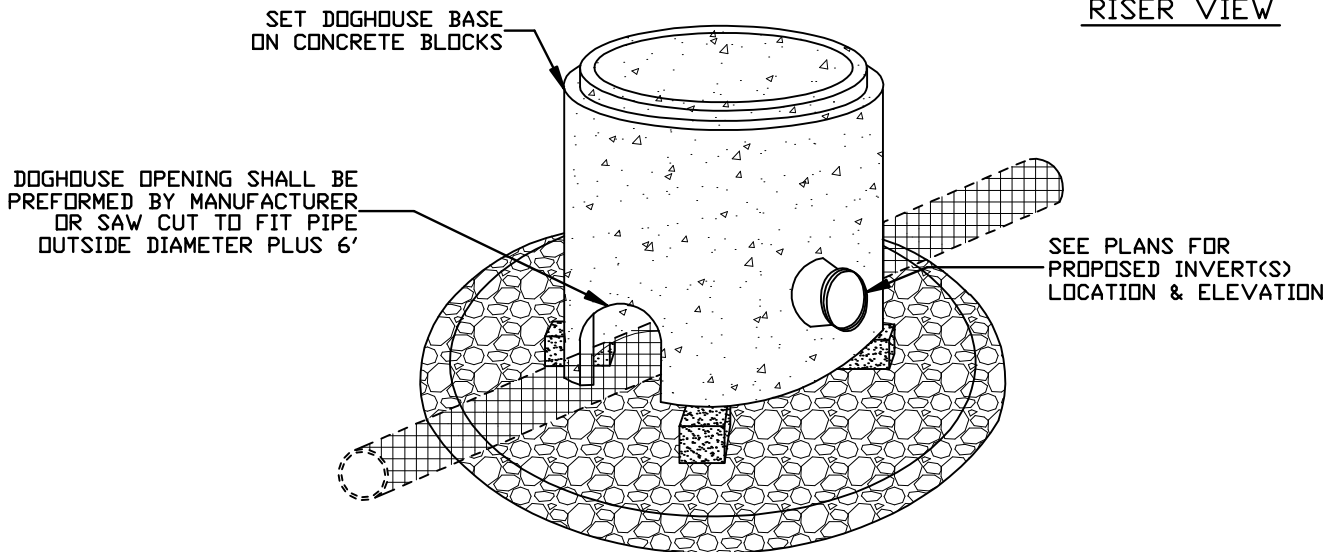

FOUNDATION/INVERT VIEW

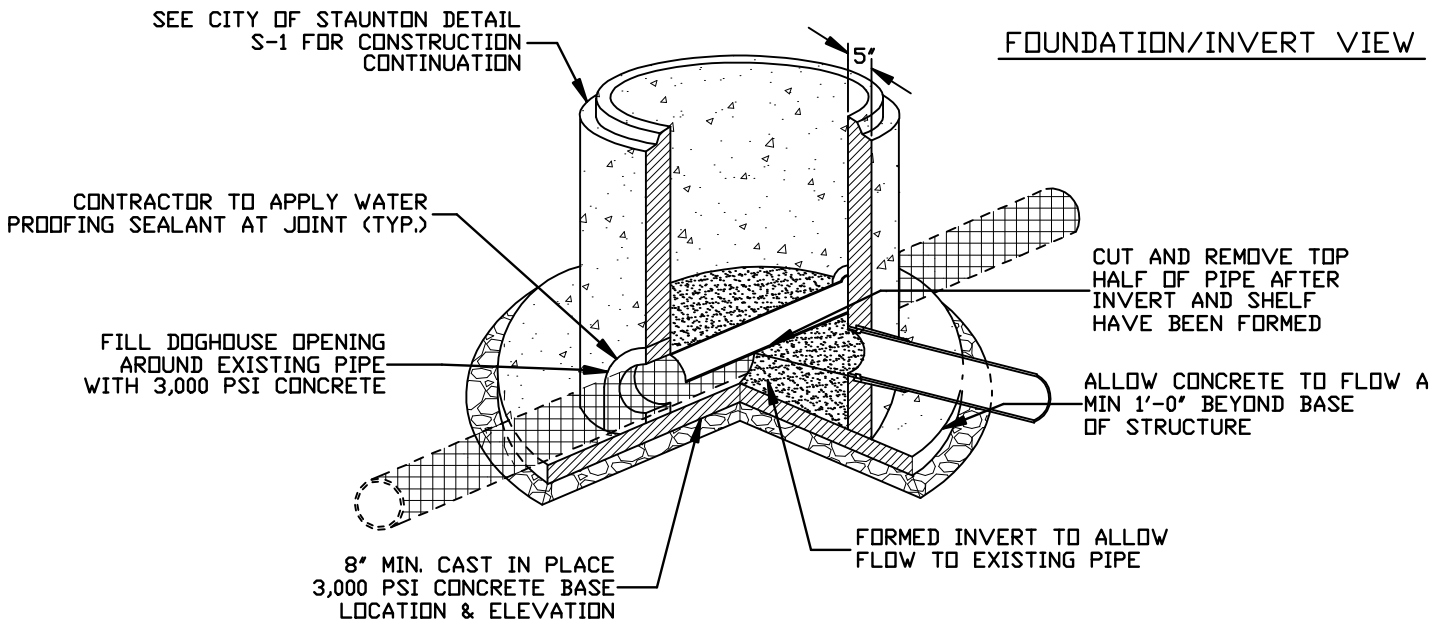

NOTE: SEE DETAIL S-3 FOR MANHOLE SIZING TABLE

**CITY OF
STAUNTON, VA**

**STANDARD PRECAST
DOGHOUSE MANHOLE**

**Draw No.
S-1A**